

ROLLING DRUM RISER

Staging Concepts' Rolling Drum Riser complements your performance stage set-up. Its understructure has dual locking casters to keep the riser in place during performances. When not in use, its understructure collapses for easy storage and transport. The Rolling Drum Riser is for use with SC90 Platforms.



Rolling Drum Riser

SC90 Platform/Decks are available in the following surface options:

- A) Poly Vinyl – black
- B) Poly Vinyl – gray
- C) Plyron – tempered hardboard
- D) Carpet – black
- E) Carpet – gray
- F) Acrylic – opaque (clear acrylic also available)

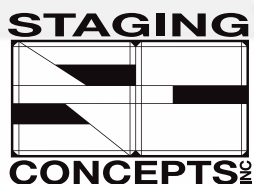
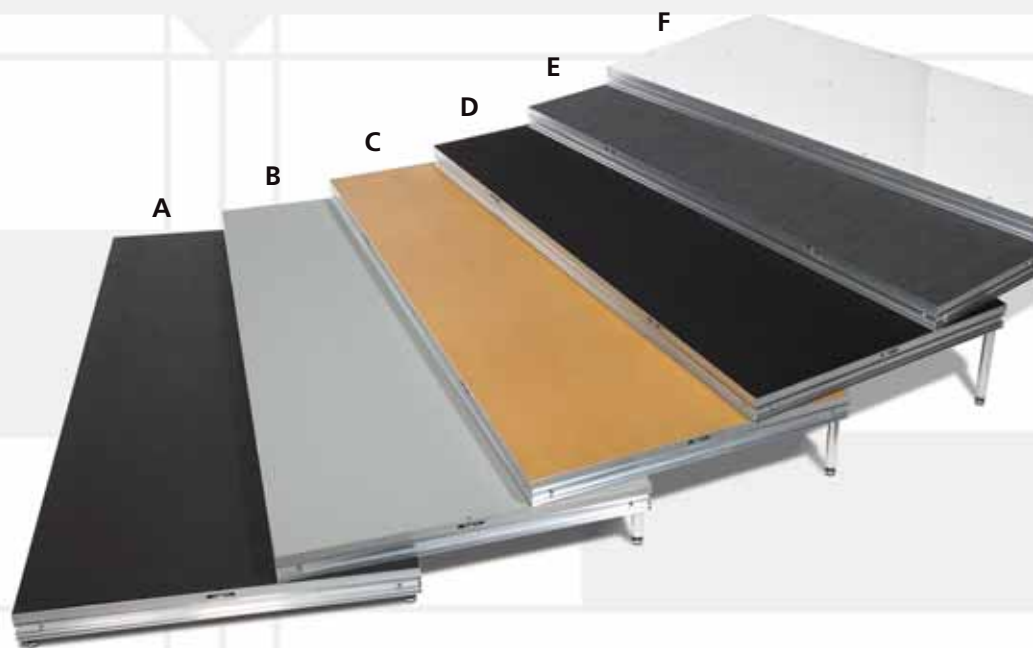

ROLLING DRUM RISER

ADVANTAGES

Efficiency

- Sets up in minutes with only two people
- When platforms are taken off, drum riser understructure folds up quickly and easily into storage position
- Locking casters allow drum riser to roll into place and lock into static position

TECHNICAL SPECIFICATIONS

Staging Concepts' Rolling Drum Riser Understructure complies with the following:

- Material: HREW 14 gauge steel tubing
- Casters: 4 inch (102mm) locking casters
- Finish: Black powder coat

DIMENSIONS, WEIGHTS, AND FINISH OPTIONS

Description	Weight (lbs/kg)
8'L x 8'W x 16"H (2.44m x 2.44m x 406mm)	45/20.4
8'L x 8'W x 18"H (2.44m x 2.44m x 457mm)	48/21.8
8'L x 8'W x 24"H (2.44m x 2.44m x 610mm)	50/22.7
8'L x 8'W x 30"H (2.44m x 2.44m x 762mm)	55/24.9

***Custom sizes available upon request*

Finish:

1. Black powder coat

ROLLING DRUM RISER UNDERSTRUCTURE SCHEMATICS

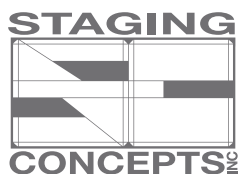
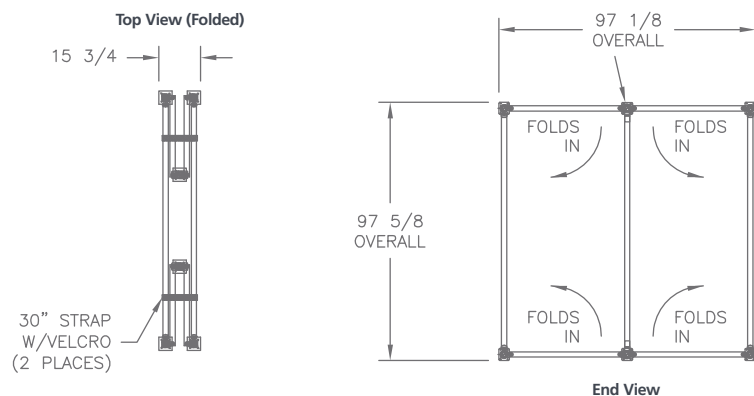

Side View



Side View